

3U VPX™ XMC Carrier Board

Key Features

TR XMC/m11 is a carrier for a single XMC module

- PCI Express® (PCIe®) Gen 3 for high bandwidth connectivity
- Simple switch configuration to enable data or expansion plane connection/isolation
- Supports 24 single ended and 20 differential XMC I/O
- Includes PCIe switch with optional non-transparent ports for use in multi-processor configurations
- Front and rear XMC I/O options
- Air-cooled and conduction-cooled options
- VITA 46.11 management controller

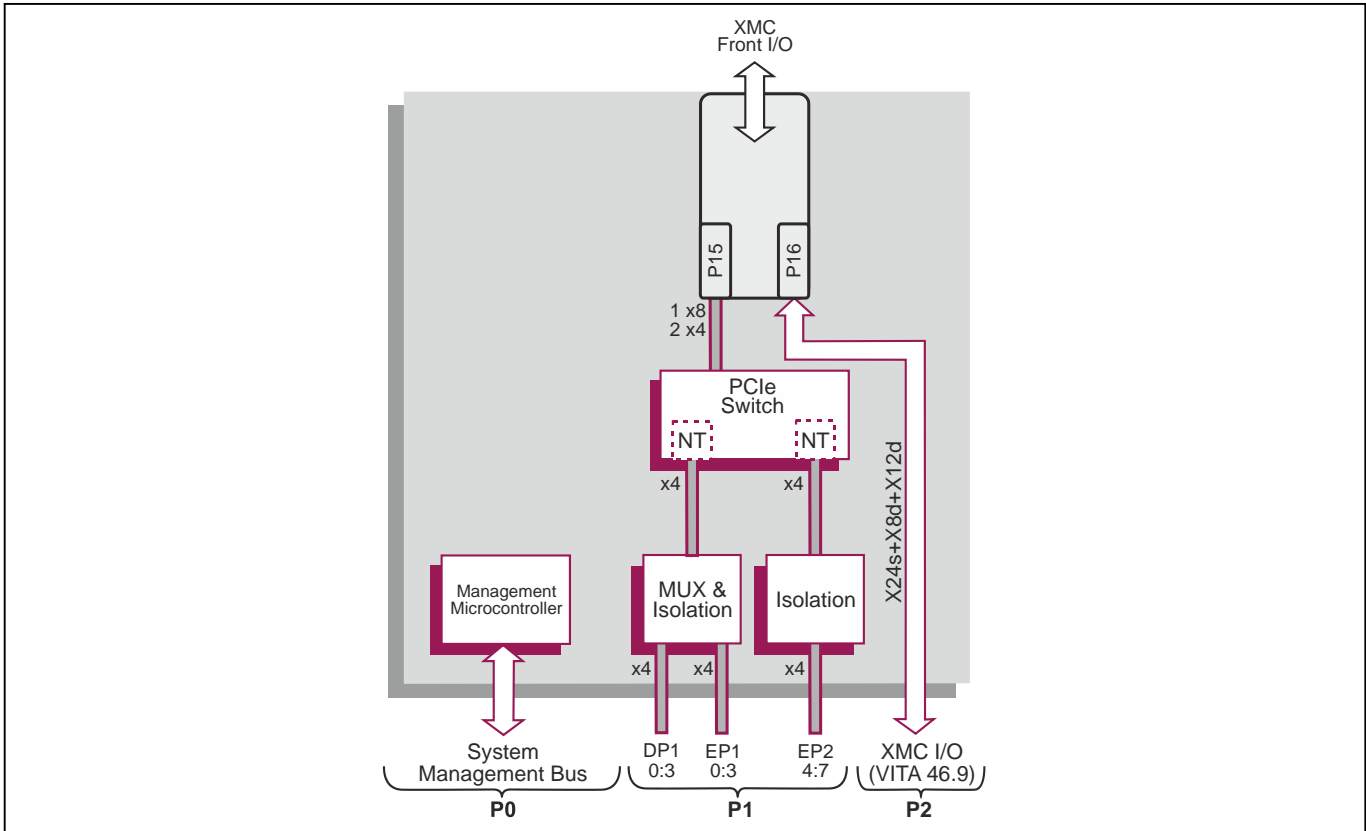

VPX XMC Carrier

- 3U VPX™ XMC Carrier supports:
 - a single size XMC module
 - End-Point Processor XMC modules
 - front panel I/O interface aperture
- complies with CMC (Common Mezzanine Card) standard IEEE 1386-2001
- XMC P16 and P15 connectors (build option), select:
 - VITA 42 XMC (color black)
 - VITA 61 XMC 2.0 (color white)
- rugged conduction-cooled VPX-REDI™ variants available:
 - see TR XMC/311-RCx datasheet
- optional rear panel transition modules

XMC Data and I/O Interfaces

- XMC module interface supports:
 - 1 x8 or 2 x4 PCI Express® (PCIe®)
 - PCIe Gen 1, Gen 2 and Gen 3
 - root complex mode
- XMC connector type (build option) determines the maximum PCIe operational speed:
 - up to Gen 2, VITA 42 connector
 - up to Gen 3, VITA 61 connector
- XMC VPWR +5V or +12V (build option)
- supports front panel I/O
- supports rear I/O via VPX P2 connector (VITA 46.9):
 - via XMC P16 connector
 - P2 pinout conforms to X24s+X8d+X12d

System Management

- Tier 2 IPMC via SM0-1 and SM2-3:
 - board temperature and voltage monitor accessed via system management

Compatible VPX System Processor Board

- 3U VPX Intel® processor based board examples:
 - TR C4x/msd board (System on Chip based on Intel® Xeon® Processor D-1500)
 - TR G4x/msd board (System on Chip based on Intel® Xeon® Processor D-1500)
 - TR E5x/msd board (6th generation Intel® Core™ Processor)
- contact your local sales office for the latest range of boards supported
- supported operating systems depend on the processor board used

VPX Backplane Interface

- P0, P1 and P2 support OpenVPX configuration
- configurable PCI Express fabric interface supports:
 - x4 PCIe port to either Data Plane 1 (DP1) or Expansion Plane 1 (EP1) (also called Data Plane 2 on some profiles)
 - x4 PCIe port to Expansion Plane 2 (EP2)
 - x8 PCIe port mode (EP1 and EP2)
 - PCIe Gen 1, Gen 2 and Gen 3
 - port isolation from PCIe Switch
 - upstream or downstream ports
 - transparent or non-transparent bridging
- compatible with OpenVPX™ (VITA 65) profiles:
 - BKP3-CEN06-15.2.2-3
 - SLT3-PAY-1F2F2U
- for advanced PCIe configurations use VPX PCIe Switch Configuration software (SW VSC/001)

Electrical Specification

- typical current consumption (XMC not fitted):
 - +5V VS3 @ 0.8A, voltage +5% / -2.5%
 - +3.3V VS2 @ 0.4A, voltage +5% / -2%
 - +3.3V AUX @ 0.12A, voltage +5% / -5%
 - +12V AUX and -12V AUX routed to XMC site

Safety

- PCB (PWB) manufactured with flammability rating of UL94V-0

Environmental Specification

- air-cooled
- operating temperatures:
 - VITA 47 Class AC1, 0°C to +55°C (N-Series)
 - -25°C to +70°C (E-Series)
- non-operating temperature:
 - VITA 47 Class C1, -40°C to +85°C
- operating altitude:
 - 0 to 15,000 feet (0 to 4,572 meters)
- relative humidity:
 - 5% to 95%, non-condensing

Mechanical Specification

- 3U VPX form-factor (VITA 46.0, VITA 48.0)
- 3.9 inches x 6.3 inches (100mm x 160mm)
- slot widths:
 - 1.0-inch (IEEE 1101.10 as per VITA 46.0)
 - 1.0-inch (VITA 48.0 as per VITA 65)
- connectors to VITA 46.0 for P0, P1 and P2
- operating mechanical:
 - shock - VITA 47 Class OS1, 20g
 - random vibration - 0.002g²/Hz