

**3U VPX-REDI™ Plug In Card (PIC) based on 11<sup>th</sup> Gen Intel® Core™ Processor**

**Key Features**

TR K9x/6sd-RCx is a rugged 3U VPX™ Plug In Card based on the 11<sup>th</sup> Gen Intel® Core™ Processor and is designed in alignment with the SOSA™ Technical Standard for I/O intensive processor PICs.



- Up to 4-core (15 W) 11<sup>th</sup> Gen Intel® Core™ Processor
- PCI Express data and expansion planes for connection to accelerator boards
- XMC site for additional compute or I/O resources
- Direct-attached solid-state storage option

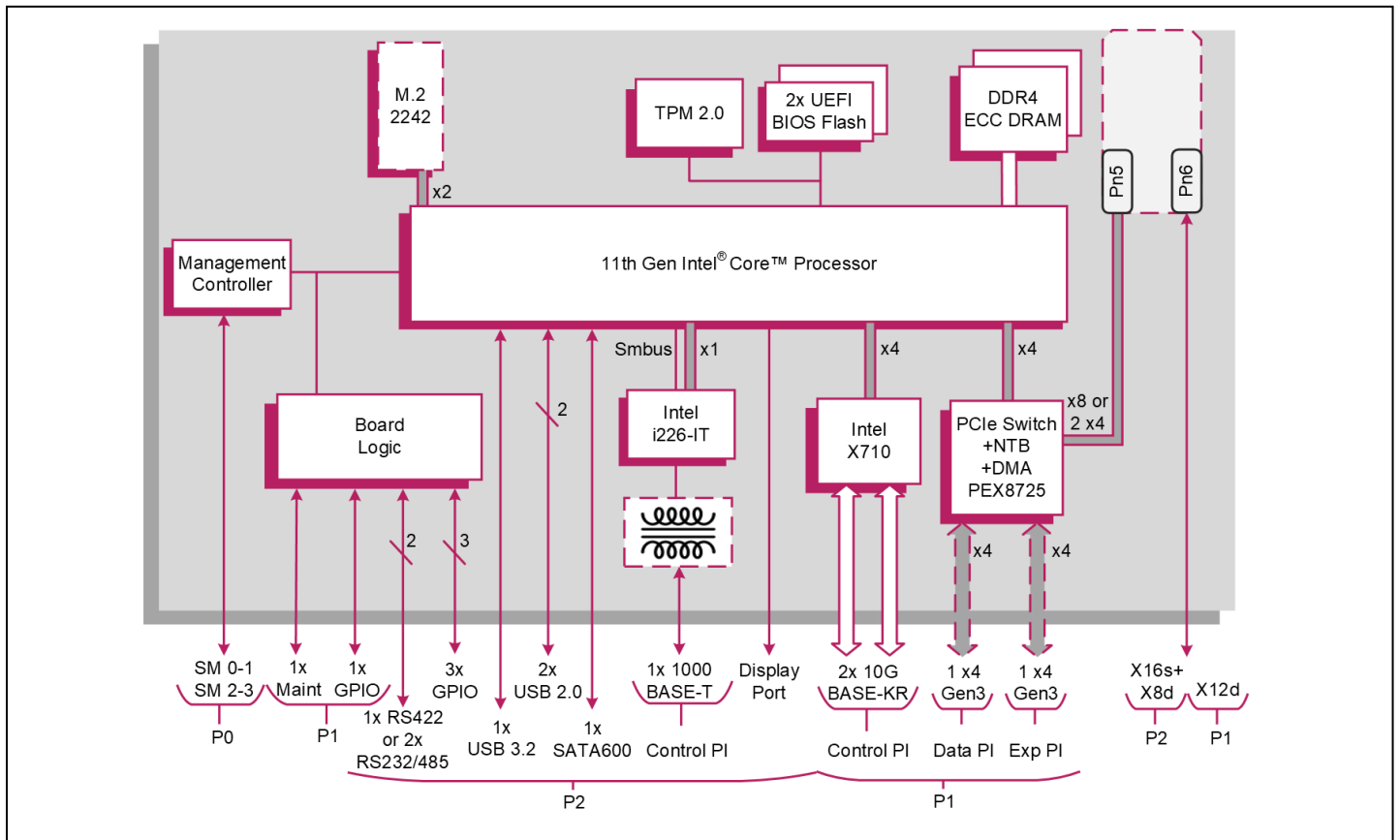

## VPX-REDI Processor Board

- conduction-cooled 3U VPX-REDI Plug In Card utilizing processors based on 11<sup>th</sup> Gen Intel® Core™ Processor
- compliant with VITA65.1 module and slot profiles:
  - SLT3-PAY-1F1F2U1TU1T-14.2.16
  - MOD3-PAY-1F1F2U1TU1T-16.2.15-2

## Central Processor

- 4-core 1.8 GHz (4.4 GHz) (15 W) Intel® Core™ i7-1185GRE Processor
- 2-core 2.2 GHz (3.9 GHz) (15 W) Intel® Core™ i3-1115GRE Processor
- Intel® Advanced Vector Extensions AVX-512
- Intel® Vector Neuro Network Instructions (VNNI)
- Intel® Iris® Xe (Gen 12) Graphics Engine with up to 96 EUs (i7-1185GRE variant)
- Intel® UHD Graphics (i3-1115GRE variant)
- range of performance/power factory build options

## DRAM

- 16 or 32 Gbytes soldered DDR4 ECC DRAM:
  - in-band ECC
  - single bit error correction
  - dual channel architecture
- accessible from processor or VPX fabric

## XMC Site

- 1x XMC site, in a single VPX slot (VITA 42.0):
  - XMC rear I/O, providing X12d+x16s+X8d
  - 1 x8 or 2 x4 PCI Express® (PCIe®)
  - PCIe Gen 1, Gen 2 and Gen 3
- XMC connector type (build option):
  - up to Gen 2, VITA 42 XMC (black color)
  - up to Gen 3, VITA 61 XMC 2.0 (white color)
- XMC VPWR +12 V
- VITA 46.9 XMC I/O pin-out

## Serial Ports

- 2x RS232 or 1x RS422 full duplex or 2x RS485 half-duplex ports accessed via P2
- 1x maintenance port accessed via P1
- Maintenance port on P1 supports RS232 or LVCMOS levels (build option)
- 16550 compatible UARTs

## Graphics/Audio Interfaces

- 1x independent graphics/audio interfaces:
  - DisplayPort v1.2 interface, supporting audio and video, via P2
  - up to 3840 x 2160 @ 60Hz, driver dependent
- support for Microsoft® DirectX 12
- support for OpenGL 4.x under Windows® and Linux®, OpenCL 3.0 and Vulkan 1.2

## Other Peripheral Interfaces

- PC RTC, long duration timer, watchdog timer
- 2x USB 2.0 and 1 x USB 3.2 Gen 1 @ 5 Gbps ports via P2
- 3x GPIO signals via P2
- 1x GPIO signal via P1

## Mass Storage Interfaces

- 1x SATA 600 via P2
- 1x M.2 SSD site supports:
  - 2230 or 2242 format module
  - x2 PCIe interface (M-key)
  - Opal security encryption
  - Write Protect
  - NVM Express® (NVMe™) logical device interface

## VPX Control Plane, Ethernet

- up to 2 x 10 Gigabit Ethernet ports via P1 (VITA 46.7):
  - supports 2 x 10GBASE-KR
  - implemented by Intel® Ethernet Controller X710 via x4 PCIe
- 1x 10/100/1000BASE-T Ethernet port via P2:
  - option for with or without magnetics
  - implemented by Intel® Ethernet Controller I226-IT
- supports IEEE 1588 Precision Time Protocol

## VPX Data/Expansion Plane, PCI Express

- PCI Express® on the VPX Fabric Connector (VITA 46.4)
- PCIe Data Plane and Expansion Plane via P1 supporting following configurations:
  - Data Plane and Expansion Plane concatenated as 1 x8 PCIe lane
  - 1 x4 PCIe lane on the Data Plane and 1 x4 PCIe lane on the Expansion Plane
  - 2 x2 PCIe lanes on the Data Plane and 2 x2 PCIe lanes on the Expansion Plane
  - factory build options available to disable the Data Plane and Expansion Plane
- PCIe interfaces support Gen 1, Gen 2 and Gen 3
- PCIe switch supports two non-transparent ports for multi-processing configurations
- 4 channel DMA engine for fast data block moves
- ports can be configured by the VPX Switch Configuration Tool, see separate datasheet
- support for PCIe backplane common clock options

## Optional Built-In Test (BIT) Support

- Power-on BIT, Initiated BIT, Continuous BIT

## System Management

- on board controller:
  - SM0-1 and SM2-3
- VITA 46.11-2022 type 3 IPMC
- option for VITA 46.11-2022 compatible Tier 1 Chassis Manager

## Board Security Packages

- Trusted Platform Module (TPM 2.0)
- option for Sanitization Utility Software Package
- option for proprietary board-level security features

## Software Support

- supports Linux® and Windows® and VxWorks®
- for other operating systems contact Concurrent Technologies for further information

## Firmware Support

- dual 32 Mbyte BIOS SPI Flash EPROMs
- UEFI boot firmware (BIOS):
  - UEFI 2.7 support
  - implements Secure Boot
- implements Intel® Boot Guard
- optional Fast Boot solution using the Intel® Slim Bootloader
- LAN boot firmware included

## Safety

- PCB (PWB) manufactured with flammability rating of UL94V-0

## Electrical Specification

- typical current figure for 16 Gbytes DRAM:
  - +12 V VS1 @ 2.2 A
  - +3.3 V AUX @ 0.35 A
- +12 V AUX and -12 V AUX routed to XMC site
- +5 V and +3.3 V are not connected

## Environmental Specification

- conduction-cooled (VITA 48.2)
- operating temperature at card edge:
  - VITA 47 Class CC4, -40°C to +85°C
- non-operating temperature:
  - VITA 47 Class C4, -55°C to +105°C
- operating altitude:
  - -1,500 to 60,000 feet (-460 to 18,300 meters)
- Rapid decompression
  - From 8,000 to 60,000 feet (from 2,440 to 18,300 meters)
- 5% to 95% Relative Humidity, non-condensing

## Mechanical Specification

- 3U VPX form-factor (VITA 46.0, VITA 48.0):
  - 3.9-inches x 6.3-inches (100 mm x 160 mm)
- slot widths (VITA 48.0):
  - 1.0-inch VPX-REDI Type 1, RCR-Series Type 1 Extended Covers Two Level Maintenance (VITA 48.2)
- connectors to VITA 46.0 for P0, P1 and P2
- captive screws available to secure front handles
- operating mechanical:
  - shock - VITA 47 Class OS2, 40 g
  - random vibration - VITA 47 Class V3, 0.1 g<sup>2</sup>/Hz