

3U VPX-REDI™ board with 40 Gigabit Optical Interconnect, based on Intel® Xeon® Processor D-1500 Family

Key Features

TR J4x/6sd-RCx is a compute intensive rugged server board. It has been developed in alignment with the SOSA™ Technical Standard. It features a processor with 12-cores, large memory capacity, local storage and support for virtualization.

- Intel® Xeon® Processor D-1500 Family
- 64 Gbytes DDR4 memory for server grade applications
- Up to 2TB direct attached storage option
- Optical interconnect (40GBASE-SR4 or 4 x 10GBASE-SR)
- 2 x 10 Gigabit Ethernet
- PCI Express® connections for point to point expansion
- Front VGA and USB ports for ease of setup

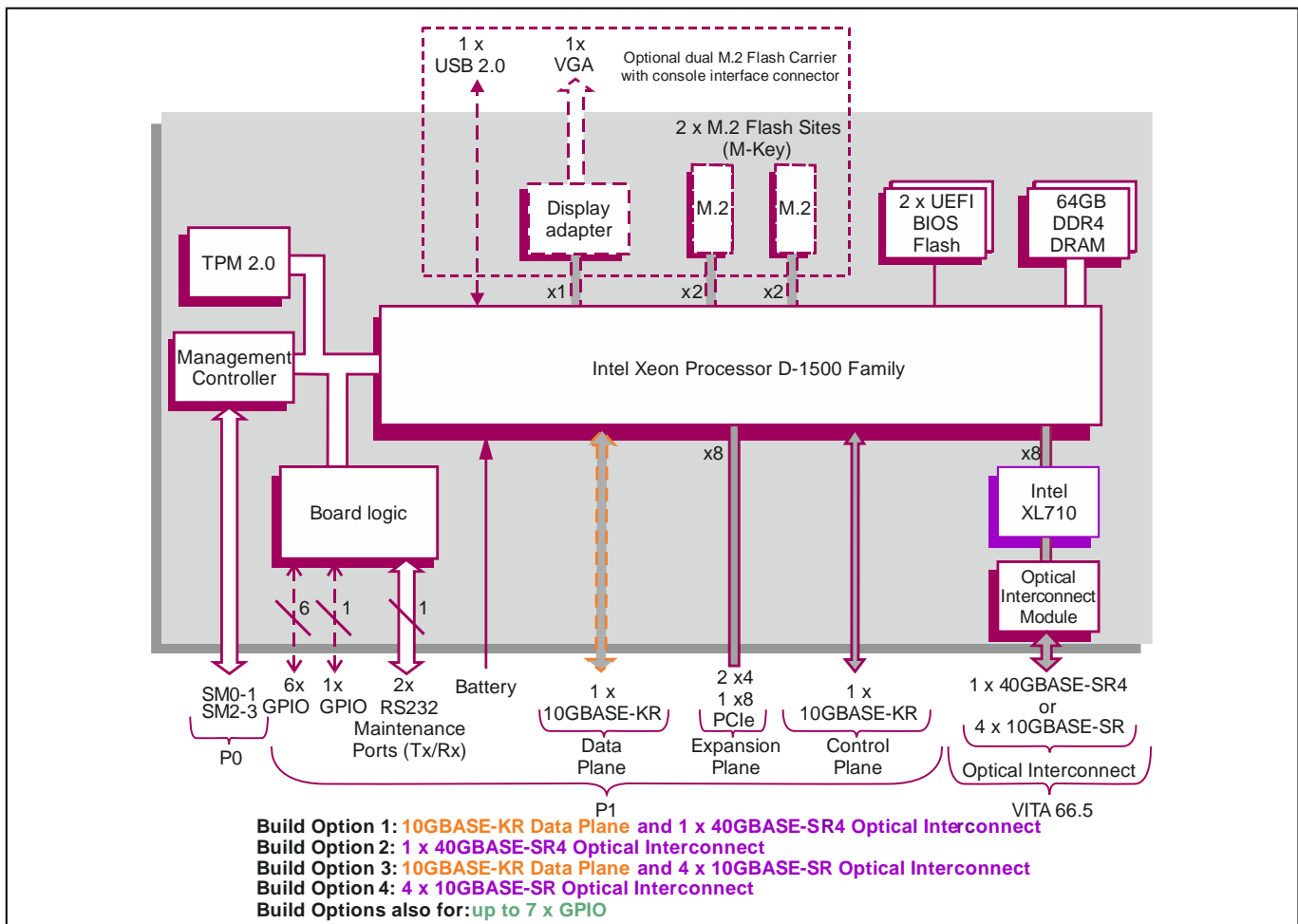

VPX-REDI Embedded Computer Board

- conduction-cooled 3U VPX-REDI computing board utilizing the Intel® Xeon® processor D-1500 family
- board supports OpenVPX™ profiles:
 - SLT3-PAY-1F1U1S1S1U1U2F1H-14-6.11-n
 - MOD3p-PAY-1F1U1S1S1U1U2F1H-16-6.11-n

Central Processor

- 12-core Intel® Xeon® processor D-1559:
 - 18 Mbytes Cache, 1.50 GHz
- Intel® Advanced Vector Extensions 2
- server class processing cores in a System-on-a-Chip package

DRAM

- 64 Gbytes soldered DDR4 ECC DRAM:
 - single bit error correction and dual bit error detection
 - peak bandwidth of up to 29 Gbytes/s
 - dual channel architecture
- accessible from processor or VPX Expansion Plane

Maintenance Serial Ports

- 2 x maintenance ports via P1:
 - supports RS232 Tx/Rx signals
 - 16550 compatible UARTs

Mass Storage Interfaces

- optional M.2 Carrier Module supporting:
 - 2 x M.2 Flash sites
 - 2242 format modules (with option for self-encryption)
 - x2 PCI Express® (PCIe®) interface (M-key)
 - NVMe Express® (NVMe™) logical device interface
 - NVMe 1.3 compatible
 - optional console interface connector (see below)

Graphical User Interface

- for board commissioning an optional on-board console interface is available via a forward facing 16-way I/O connector:
 - supported on the M.2 Carrier Module
 - VGA interface (up to 1920 x 1080 @ 60Hz)
 - USB 2.0 port for user interface
 - separate adapter cable available with standard VGA and USB connectors

Other Peripheral Interfaces

- PC RTC, long duration timer, watchdog timer
- build options: up to 1 x GPIO or up to 7 x GPIO signals via P1

VPX Optical Interconnection (up to 40G)

- VPX Optical Interconnection supports either:
 - 1 x 40GBASE-SR4 (build option 1 or 2)
 - 4 x 10GBASE-SR (build option 3 or 4)
- compatible with OpenVPX module profiles
- optical interface implemented by Intel® Ethernet Controller XL710-BM1 (via x8 PCI Express Gen 3 port) and optical interconnect module (VITA 66.5 Style B or C compatible in position P2A with MM12 MT location A)

VPX Data Plane, 10G Ethernet (optional)

- VPX Data Plane interface supports:
 - 1 x 10GBASE-KR
 - build option 1 or 3 (see block diagram)
- compatible with OpenVPX module profiles

VPX Control Plane, 10G Ethernet

- VPX Control Plane interface supports:
 - 1 x 10GBASE-KR
- compatible with OpenVPX module profiles

VPX Expansion Plane, PCIe

- configurable PCIe VPX Expansion Plane interface (VITA 65) supports:
 - 1 x8 or 2 x4 PCIe ports
- compatible with OpenVPX module profiles
- PCIe interface supports Gen 1, Gen 2 and Gen 3
- 4 channel DMA engine for fast data block moves
- ports can be configured by the VPX Switch Configuration Tool, see separate datasheet

System Management

- VITA 46.11 IPMC on board controller:
 - SM0-1 and SM2-3
 - CPU temperature and voltage monitor accessed via System Management interface
- option for Tier 1 Chassis Manager

Board Security Features

- Trusted Platform Module (TPM 2.0)
- option for Sanitization Utility Software Package
- option for proprietary board-level security features

Optional Built-In Test (BIT) Support

- Power-on BIT, Initiated BIT, Continuous BIT

Software Support

- supports Linux® and Windows®
- for other operating systems contact Concurrent Technologies for further information, e.g. VxWorks®
- options available for enhanced PCIe drivers

Firmware Support

- dual 16 Mbyte BIOS Flash EPROMs
- UEFI boot firmware (BIOS):
 - UEFI 2.4 support
 - includes Compatibility Support Module
 - implements Secure Boot
- optional Fast Boot solution using the Intel® Firmware Support Package (FSP)
- LAN boot firmware included

Safety

- PCB (PWB) manufactured with flammability rating of UL94V-0

Electrical Specification

- typical current consumption for 12-core processor (1.50 GHz):
 - +12V VS1 @ 3.8A
 - +3.3V AUX @ 0.3A

Environmental Specification

- conduction-cooled (VITA 48.2)
- operating temperature at card edge:
 - VITA 47 Class CC4, -40°C to +85°C
- non-operating temperature:
 - VITA 47 Class C4, -55°C to +105°C
- operating altitude:
 - -1,500 to 60,000 feet (-460 to 18,300 meters)
- rapid decompression
 - from 8,000 to 60,000 feet (from 2,440 to 18,300 meters)
- 5% to 95% Relative Humidity, non-condensing

Mechanical Specification

- 3U VPX form-factor (VITA 46.0, VITA 48.0):
 - 3.9 inches x 6.3 inches (100mm x 160mm)
- slot width (VITA 48.0):
 - 1.0 inch VPX-REDI Type 1, RCR-Series Type 1 Extended Covers Two Level Maintenance (VITA 48.2)
- connectors to VITA 46.0 for P0 and P1
- captive screws available to secure front handles
- operating mechanical:
 - shock - VITA 47 Class OS2, 40g
 - random vibration - VITA 47 Class V3, 0.1g²/Hz