

Rugged 3U VPX™ Position, Navigation and Timing (PNT) Plug In Card

Key Features

PR A11/6sd-RCx is a rugged 3U VPX™ Plug In Card (PIC) for high accuracy and resilient Position, Navigation and Timing (PNT). It is designed in alignment with the SOSA™ Technical Standard to be suitable for future Electronic Warfare and Cyber Security applications.

- 4-core Arm® v8 A72 Processor for control and management
- Integrated multi-constellation, multi-frequency GNSS module with interference and jamming mitigation
- Chip Scale Atomic Clock (CSAC) and Inertial Measurement Unit (IMU) for assured PNT
- Differential radial clock distribution
- Coaxial Antenna and Timing signals in P2 aperture

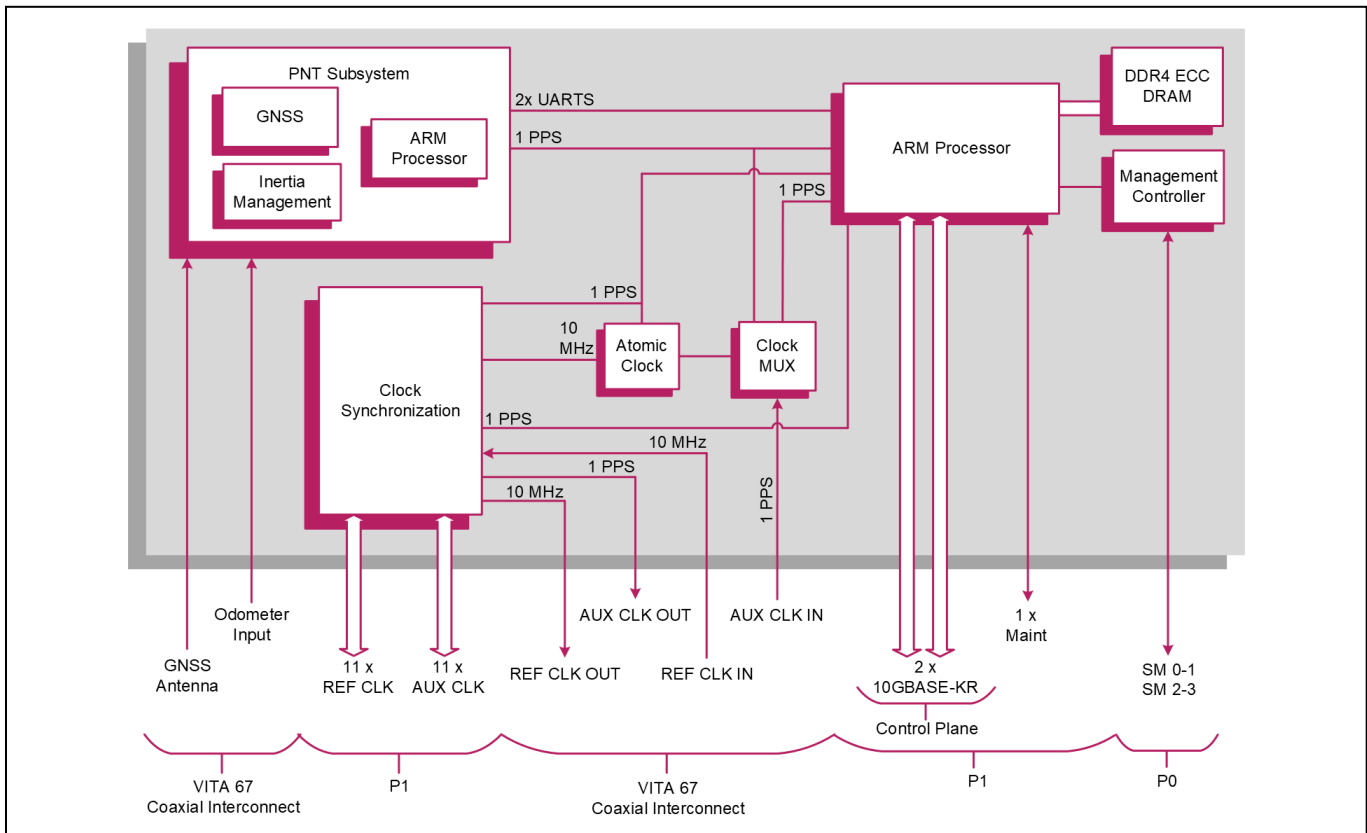

VPX PNT Plug In Card

- rugged conduction-cooled 3U VPX™ PIC
- compatible with the OpenVPX™ profiles:
 - SLT3x-TIM-2S1U22S1U2U1H-14.9.2-1
 - MOD3x-TIM-2S1U22S1U2U1H-16.9.2-2
- aligned to SOSA™ Technical Standard

Control and Management Processor

- 4-core Arm® v8 A72 Processor
- soldered DDR4 ECC DRAM
- manages configuration, control and distribution of all PNT parameters and settings

GNSS Receiver

- configurable satellite constellation tracking:
 - GPS: L1C/A, L2C
 - GLONASS: L1OF, L2OF
 - Beidou: B1I, B2I
 - Galileo: E1B/C, E5B
 - QZSS: L1C/A, L1S, L2C
 - SBAS: L1C/A
- configurable mode SBAS, RTK, DGPS
- 100 Hz measurement output

Chip Scale Atomic Clock

- frequency: 10.0 MHz
- 1 PPS output and 1 PPS input for synchronization
- ±5.0E-11 accuracy at shipment
- 9.0E-10 /mo Aging Rate
- 1.5E-11 @ 1000 s Short Term Stability

Inertial Measurement Unit

- 6 degrees of freedom IMU:
 - 3-axis accelerometer
 - 3-axis gyrometer
- optional odometer integration

Backplane Ethernet Ports

- Control Plane:
 - 2x 10GBASE-KR Ethernet port via P1
- NTP and PTP support
- UDP broadcast of NMEA or raw packets via one or both Control Plane ports
- Publisher/Subscriber model of data distribution

Other Peripheral Interfaces

- 1x Maintenance port accessed via P1
- 1x USB 2.0 diagnostic port via front panel

Timing signals

- LVDS radial clocks (P1)
 - 11x differential REF clocks (output selectable: 10 MHz, 25 MHz, 50 MHz or 100 MHz)
 - 11x differential AUX clocks (output selectable: 1 PPS or 10 MHz, 25 MHz, 50 MHz or 100 MHz)
- RF timing (VITA 67.3 Aperture)
 - 1x GNSS antenna
 - AUX CLK in/out
 - REF CLK in/out

Time Synchronization

- system time synchronization between GNSS and CSAC
- RTC with VBAT connection

VITA 67.3 Aperture

- 10 SMPM and 14 SMPM connector option

Software Functionality

- IEEE802.1AS Precise Time Protocol (PTP) support, allowing synchronization of systems to within 100 ns of each other
- Network Time Protocol (NTP) Tier-1 sever or client support:
 - allowing synchronization to within 1 ms or better
 - the PIC can act as a Stratum 1 NTP server
- Command Line Interface (CLI) available via Maintenance Port, allowing easy user configuration
- SMIC Interface

Security

- Trust Architecture 2.1
- Secure Boot

System Management

- VITA 46.11 Tier-3 IPMC on-board controller:
 - SM0-1 and SM2-3
 - temperature and voltage monitor accessed via System Management interface
 - PNT status monitored via System Management interface

Safety

- PCB (PWB) manufactured with flammability rating of UL94V-0

Electrical Specification

- typical current figure:
 - +12 V VS1 @ TBD A
 - +3.3 V AUX @ TBD A
- +5 V and +3.3 V are not connected

Environmental Specification

- conduction-cooled (VITA 48.2)
- operating temperature at card edge:
 - VITA 47 Class CC3, -40°C to +70°C (RCx-Series)
- non-operating temperature:
 - VITA 47 Class C4, -55°C to +105°C
- operating altitude:
 - -1,500 to 60,000 feet (-460 to 18,300 meters)
- relative humidity: 5% to 95%, non-condensing

Mechanical Specification

- 3U VPX form-factor (VITA 46.0, VITA 48.0):
 - 3.9 inches x 6.3 inches (100 mm x 160 mm)
- slot width (VITA 48.0):
 - 1.0-inch VPX-REDI Type 1, RCR-Series, Type 1 Extended Covers Two Level Maintenance (VITA 48.2)
- connectors to VITA 46.0 for P0 and P1
- captive screws available to secure front handles
- operating mechanical:
 - shock - VITA 47 Class OS2, 40 g
 - random vibration – VITA 47 Class V3, 0.1 g²/Hz